





ASSEMBLY INSTRUCTION DINING TABLE

No	LIST OF HARDWARE	Q.TY(pcs)
1	Bolts M8 x 60 	8
2	Flat Washer $\phi 8.5/20$ 	8
3	Lock Washer $\phi 8.5/13$ 	8
4	Wrench K13 	1



Note : Legs must be attached with corresponding leg attachment point.
A=A, B=B, C=C, D=D.

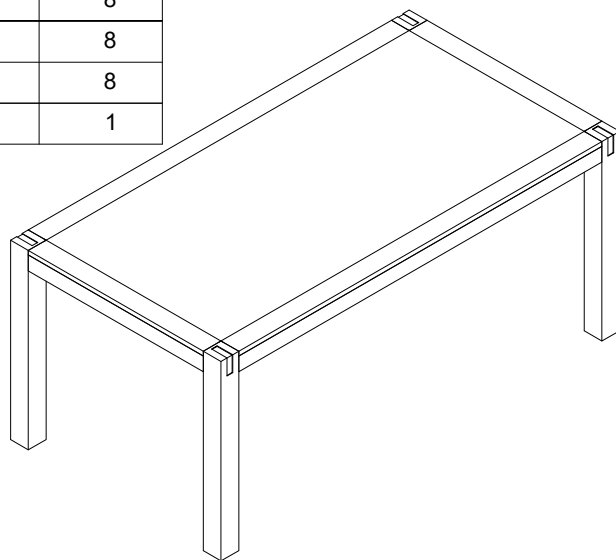
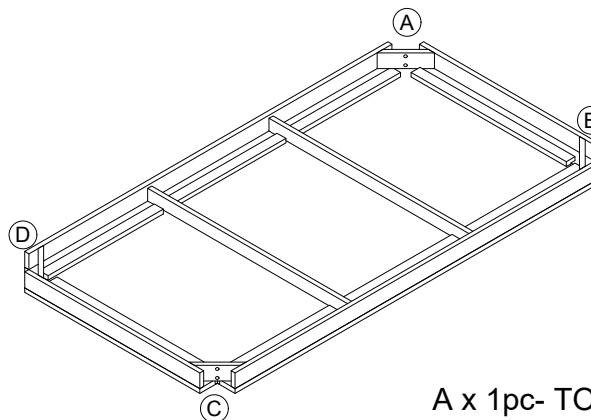

A x 1pc- TOP

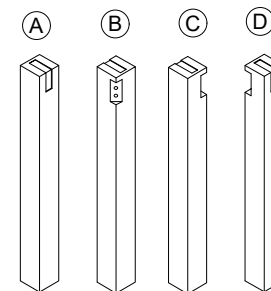

B x 4pcs - LEG

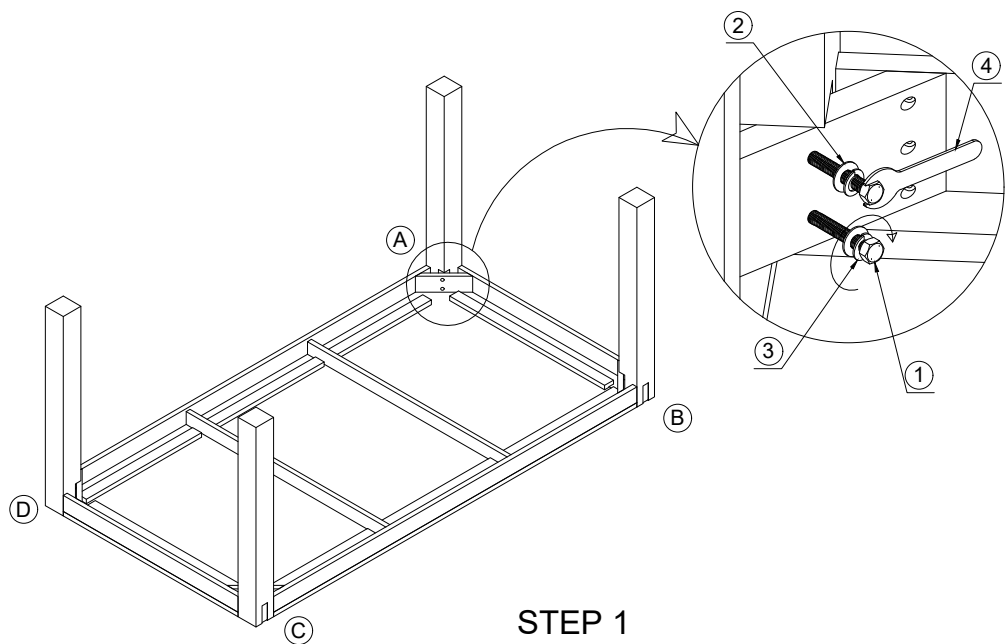

STEP 1

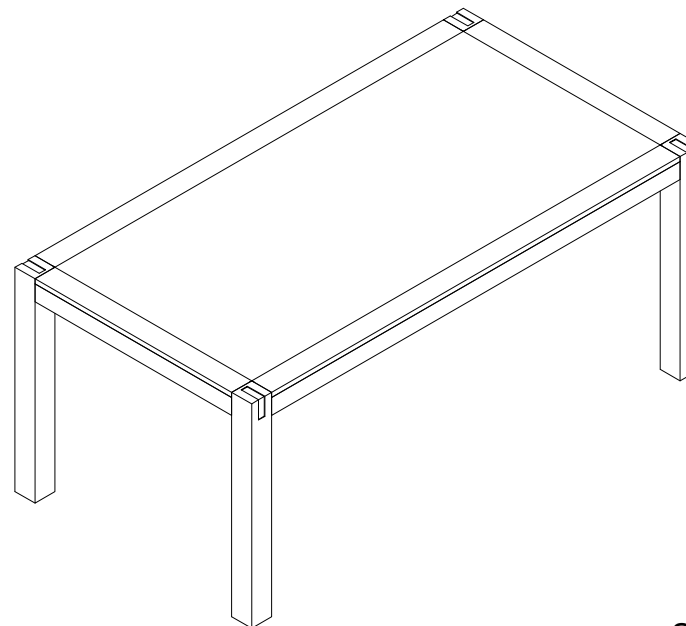

STEP 2